

Authorised Dealer;
 PUSHKARNA SALES PVT LTD.
 4772, Hauz Qazi, Delhi-110006.
 Telefax : 011-23217239/23216378.
 Emails : psp1@airtelmail.in,
 sales@pushkarnasales.com
 Site : www.pushkarnasales.com

Fabricated Strainer

Strainer Limiting Conditions:

Max. Working Pressure and Temperature as per Flange rating limits

Sizes:

15, 20, 25, 40, 50, 65, 80, 100, 125, 150, 200, 250 & 300 NB

End Connections:

Flanged to B.S. 10, Table 'H', 'J' & 'K'
 ANSI 150.300, & 600.
 DIN – ND -16, 25 & 40.
 Available with IBR certificate on request.

Materials:

No	Part	IBR	Non-IBR
1	Body	ASTM-A-106Gr. B	ERW-Class 'C'
2	Inlet	ASTM-A-106Gr. B	ERW-Class 'C'
3	Outlet	ASTM-A-106Gr. B	ERW-Class 'C'
4	Screen	AISI 304	AISI 304
5	Blank flange	I S 2002	I S226
6	Drain plug	3/4" BSPT C Steel	3/4" BSPT C. Steel
7	Gasket	Reinforced exfoliated graphite	

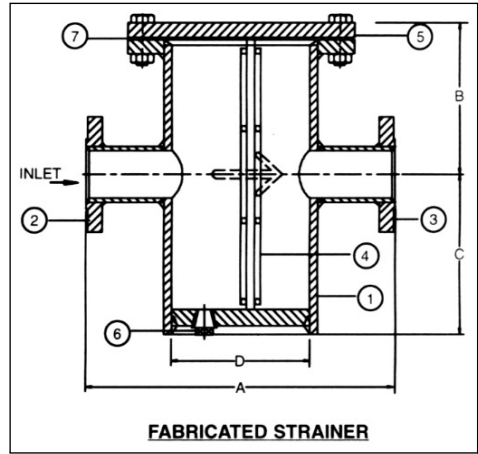

8.5

Size	Dimensions			
	A	B	C	D
15	292	124	130	76.2
20	292	124	130	76.2
25	292	124	130	76.2
40	292	124	130	76.2
50	300	160	180	76.2
65	368	175	180	101.6
80	368	180	184	101.6
100	500	270	300	152.4
125	550	300	310	203.2
150	622	266	269	254
200	673	381	463	304.8
250	700	400	500	355.6
300	925	560	760	457.2

General tolerance ± 2%

Filtering Element:

Stainless Steel Sheet with 0.8 mm. perforations supported in a mild steel frame.

Available spares:

Stranger Screen, 0.8 perforations, SS304 material.

How to order :

Always order spares by using the description given in the column headed Availablespaces and indicate the size of the strainer.