

# spirax

Authorised Dealer:  
 PUSHKARNA SALES PVT LTD.  
 4772, Hauz Qazi, Delhi-110006.  
 Telefax : 011-23217239/23216378.  
 Emails : psp1@airtelmail.in,  
 sales@pushkarnasales.com  
 Site : www.pushkarnasales.com

## Inverted Bucket Steam Traps HM 00, HM 10, HM 12

### Description:

The Spirax MM Series of Cast Iron Inverted Bucket steam traps is designed so that they can be fitted into horizontal pipelines. They are maintainable in line and are complete with integral strainer screen.

### Sizes and pipe connections:

HM00 - 15 NB, screwed BSPT/ NPT

HM10 - 20 NB, screwed BSPT/ NPT

Hm12 - 25 NB, screwed BSPT/ NPT

### Limiting Conditions:

Maximum body design conditions \_\_\_\_\_ 13 bar g

PMA-max. Allowable pressure \_\_\_\_\_ 13 bar g

TMA-max. Allowable temperature \_\_\_\_\_ 220°C.

Cold hydraulic test pressure \_\_\_\_\_ 26 bar

Maximum operating conditions depend upon orifice size.

Δ PMX - max. differential pressure

**Model** \_\_\_\_\_ ΔPMX (bar)

HM 00 / 6 \_\_\_\_\_ 10.0

HM 00 / 7 \_\_\_\_\_ 8.5

HM 00/8 \_\_\_\_\_ 4.0

HM1 OH \_\_\_\_\_ 12.5

HM10/8 \_\_\_\_\_ 8.5

HM 10/10 \_\_\_\_\_ 4.0

HM 12/7 \_\_\_\_\_ 13.0

HM 12/10 \_\_\_\_\_ 8.5

HM 12/12 \_\_\_\_\_ 4.0

### Materials:

Sr.	Part	Material	Standard
1	Cover	Cast Iron	IS 210 FG220
2	Cover Studs & Nuts	Carbon Steel	IS 1367
3	Body	Cast-Iron	IS 210 FG220
4	Bucket	Stainless Steel Type 304	ASTM - A - 240
5	Valve Guide Plate Screws	Stainless Steel Type 304	IS 1364
6	Valve Guide Plate	Stainless Steel Type 304	ASTM-A-240
7	Cover Gasket	Reinforced exfoliated graphite	
8	Valve Seat	Stainless Steel Type 304	ASTM - A - 276
9	Valve	Stainless Steel Type 304	ASTM - A - 276
10	Valve Lever	Stainless Steel Type 304	ASTM - A - 240
11	Ferrule	Stainless Steel Type 304	ASTM - A - 213
12	Strainer Screen	Stainless Steel Type 304	ASTM - A - 240
13	Strainer Cap	Stainless Steel / Cast Steel	
14	Plug	Carbon Steel	

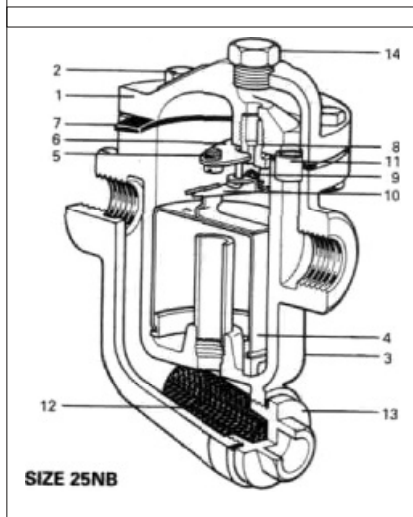
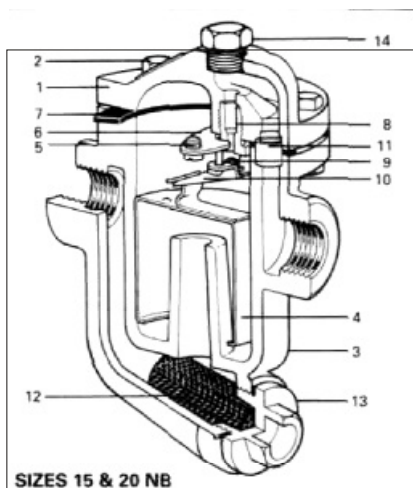

6.4

**Dimensions (approx.) mm.**

Size	A	B	C	F	G	H	Weight (kg)
15 NB	130	120	110	75	100	65	5.25
20 NB	130	120	150	93	117	65	6.00
25 NB	180	165	170	132	127	85	11.50

**Installation:**

The trap must be installed with the body upright so that the bucket is rising and falling vertically. The inlet and outlet connections should be in a horizontal plane. With the trap installed below the drain point so that a water seal can be maintained around the open end of the

**How to specify:**

20 NB HM 10/7 SPIRAX Steam Trap with screwed BSPT connections, IBR

**Spare parts:**

The spare parts available are shown in heavy outline. Parts drawn in broken line are not supplied as spares.

**AVAILABLE SPARE**

- Valve and seat Assembly \_\_\_\_\_ A, B, C (2 off) D
- Bucket \_\_\_\_\_ E
- Cover Gasket & Ferrule  
(pkt. of 3 each) \_\_\_\_\_ F, G
- Strainer Screen \_\_\_\_\_ H
- Set of Cover Studs & Nuts \_\_\_\_\_ (set of 6) J

**How to Order**

Always order spares by using the description given in the column headed Available Spare and stating the size and series of the trap.

Example 1 - Valve and Seat Assembly for 15 NB SPIRAX Steam Trap Series HMOO/7.

**How to Fit Valve and Seat Assembly:**

Isolate trap, remove cover by undoing cover nuts. Unhook the bucket from the valve lever A. Remove the valve seat B. Remove the valve guide plate C by undoing the two screws D. Screw in new valve seat, using a little jointing paste on the threads and making sure the joint faces are clean. Fix new valve guide plate in position by new screws which are supplied, hook new valve lever over pins on valve guide plate and centralise valve to the orifice and tighten screws.

**Recommended tightening torques**

Seat B	15 & 20 NB	23-27 Nm
	25 NB	80-88 Nm
Studs & Nuts J	15 & 20 NB	25-28 Nm
	25 NB	85-95 Nm
Strainer	15&20NB	90-100 Nm
Cap	25 NB	125-145 Nm

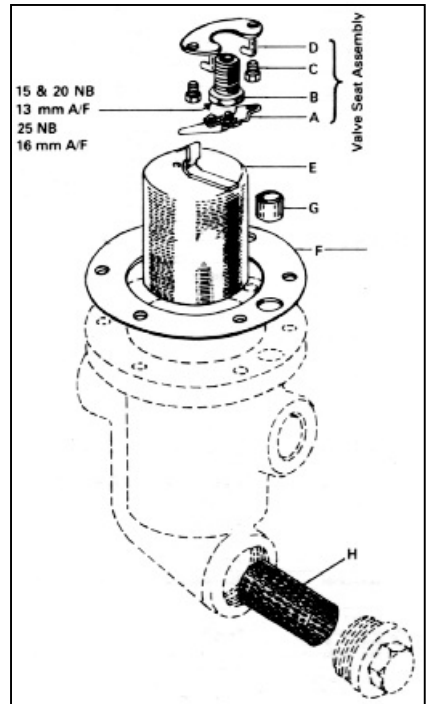
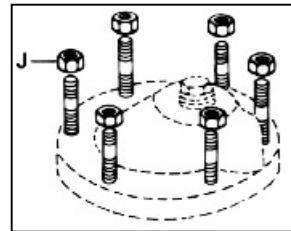
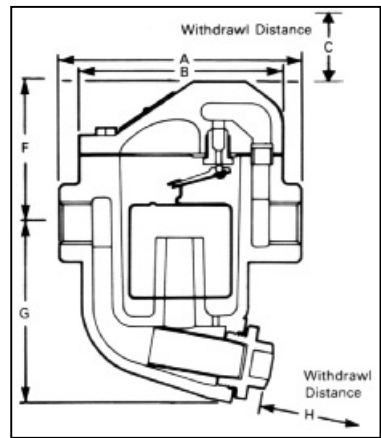

**Capacities :**  
(15 NB - HM 00)

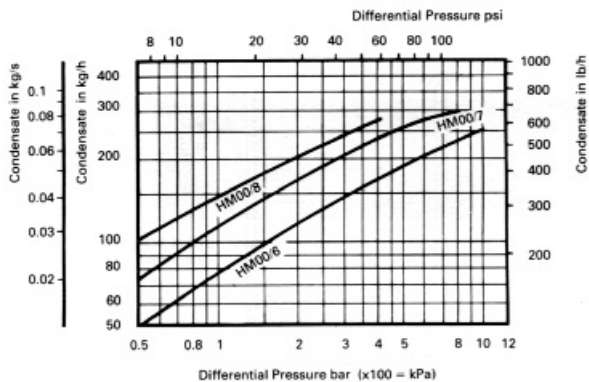

**Capacities :**  
(20 NB - HM 10)

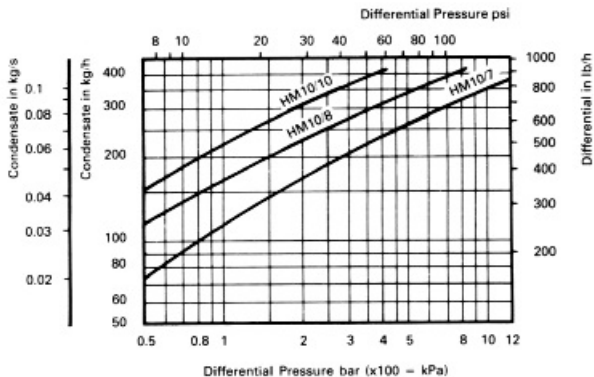

**Capacities :**  
(25 NB - Hm 12)

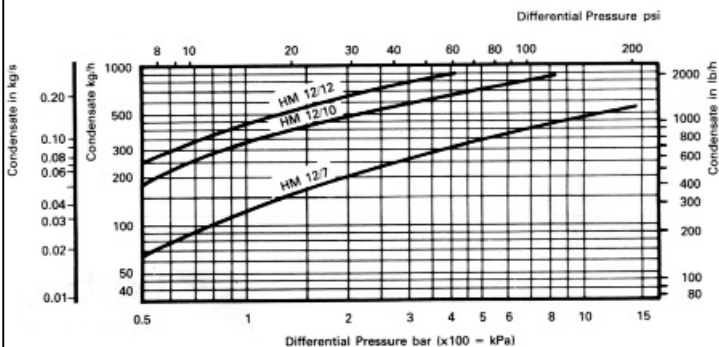

Typical Application:

