



RASAI

LINED BALL VALVES

About Ourselves

RASAI is an International Company. Founded in 1981, Rasaii Flow Lines has been engaged in design, Manufacture and Distribution of High Tech Valves.

Over the last 20 years, **RASAI** has been providing its Valves for various end - uses and applications in refineries, petrochemicals, fertilizers, sugar, paper, steel, cement, chemical and pharmaceutical industries as well as in power plants around the world.

RASAI's design and engineering are novel and unique and conform to international standards and specifications. Our products are tested for various standards and ratings and are superior in quality.



Manufactured by :
RASAI FLOW LINES
34, NEW STREET, MADUVANKARAI,
GUINDY, CHENNAI 600 032. INDIA.
Tel: + 91-44-2244 7285, + 91-44-2245 7658
Fax: + 91-44-2244 7616
Email: rfi@md2.vsnl.net.in
URL: www.rflexports.com

Our Distributor / Representative :
Pushkarna Sales Pvt Ltd.
4772. Hauz Qazi. Delhi-06.
Telefax: 011-23216378/23217239.
Email: sales@pushkarnasales.com
Site: www.pushkarnasales.com

Designed & Printed by : The Graphic Design Shop
© 91-44-2847 4706, 5210 3114 www.designshopbiz.com



RASAI

LINED BALL VALVES

WORLD'S BEST ELASTOMER SUPER SEAT[®] LINED

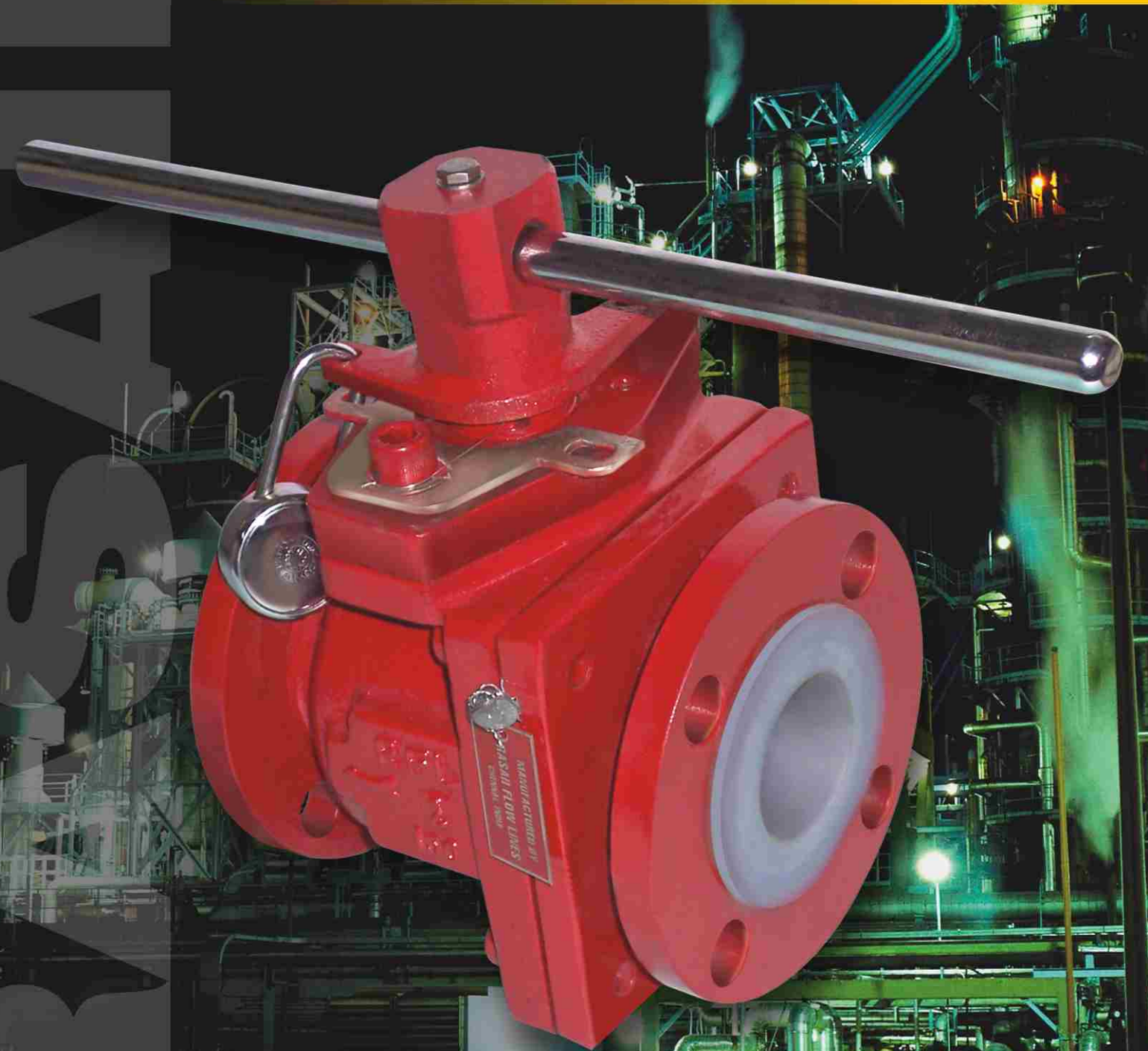

INNOVATIVE IN DESIGN, IMPECCABLE IN PERFORMANCE

SECTIONAL VIEW WITH DESIGN FEATURES

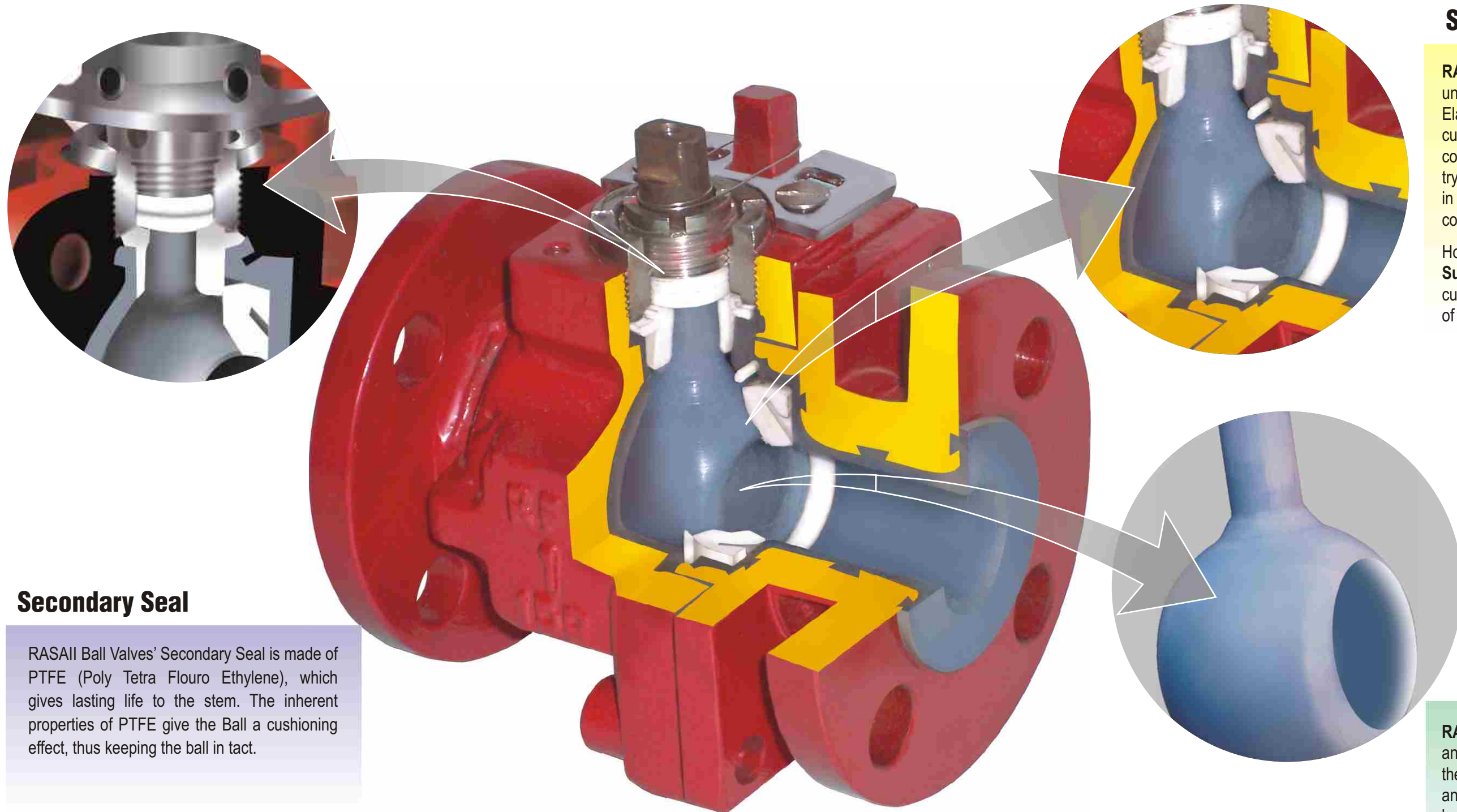

Secondary Seal

RASAI Ball Valves' Secondary Seal is made of PTFE (Poly Tetra Fluoro Ethylene), which gives lasting life to the stem. The inherent properties of PTFE give the Ball a cushioning effect, thus keeping the ball in tact.

Seat design

RASAI Ball Valves' **Super Seat**® design is unique in nature and is copyrighted. The Elastomer **Super Seat**® gives the ball a cushioning effect whenever it comes into contact with the body. The ball is always trying to reach the body while the valve is in operation due to intense pressure conditions inside the valve.

However, the unique design of Elastomer **Super Seat**® gives the ball an added cushioning effect, thus elongating the life of the valve.

Integral Ball and Stem design

RASAI Ball Valves' design features the ball and stem as an integral piece, thus giving them longer life besides ensuring smooth and trouble-free operation. The two-piece ball and stem often tend to break down quickly. RASAI has been the technological innovator to offer ball and stem as an integral unit.

COMPARISON OF ELASTOMER Super Seat[®] DESIGN

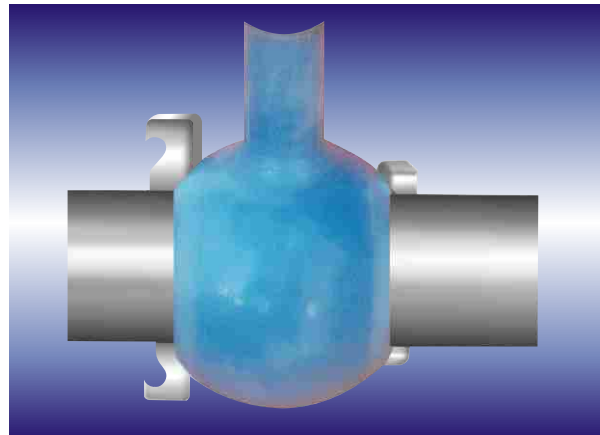

RASAI Elastomer **Super Seat[®]** shown (in the picture) along with other competitors' Seat Design for comparative analysis. End – users looking for reliable, superior and longer lasting Ball Valves will naturally choose and specify RASAI Ball Valves.

Super Seat[®], How it works ?

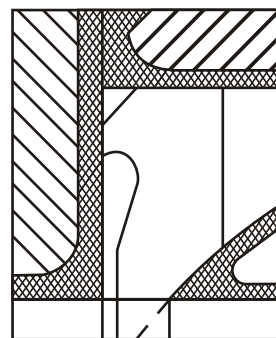

Valve in Open Position

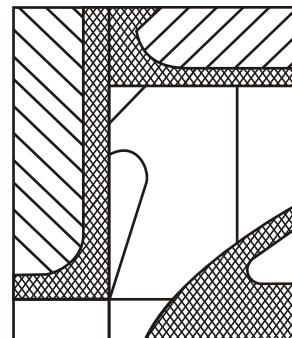

Valve in Closed Position

RASAI innovation is novel by way of Elastomer characteristics built into the design of our valves. When the Ball rotates, the minute gap between the end piece and the surface face gives the Ball a cushioning effect, whenever the valve is closed. (illustration of operational view open / closed)

Resultant breakage of Two-Piece Ball Design

Broken ball and stem

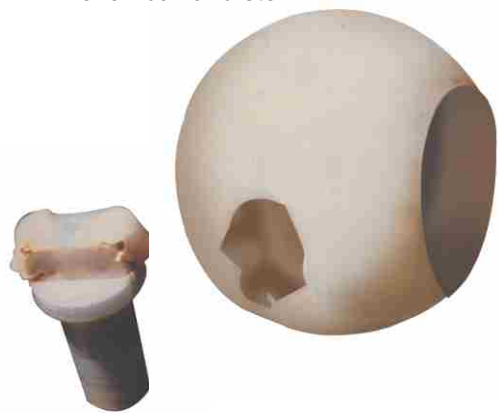

RASAI Ball and Stem design being an integrated one-piece unit (as per the picture on right hand) offers longer life to our valves. In addition, the unique design of the Elastomer **Super Seat[®]** gives our valves added life. Use of a two-piece ball and stem design often results in breakdown (as shown in the picture on left), shortening the life of the valves. RASAI integral ball and stem design assures longer life and trouble-free operation, compared to other lined ball valve manufacturers' two-piece design.

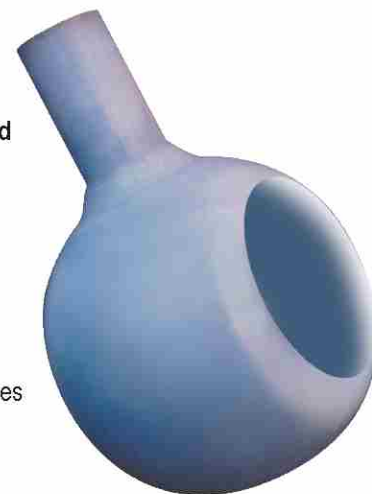

RASAI integrated ball and stem design

'V' Notch Control Lined Ball Valve for liner application

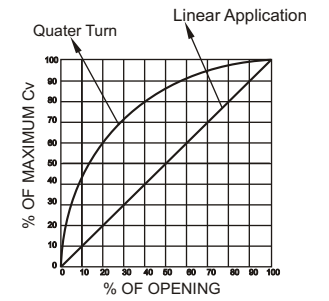
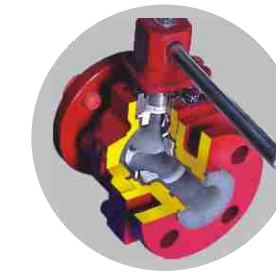

SECTIONAL LINE DRAWING

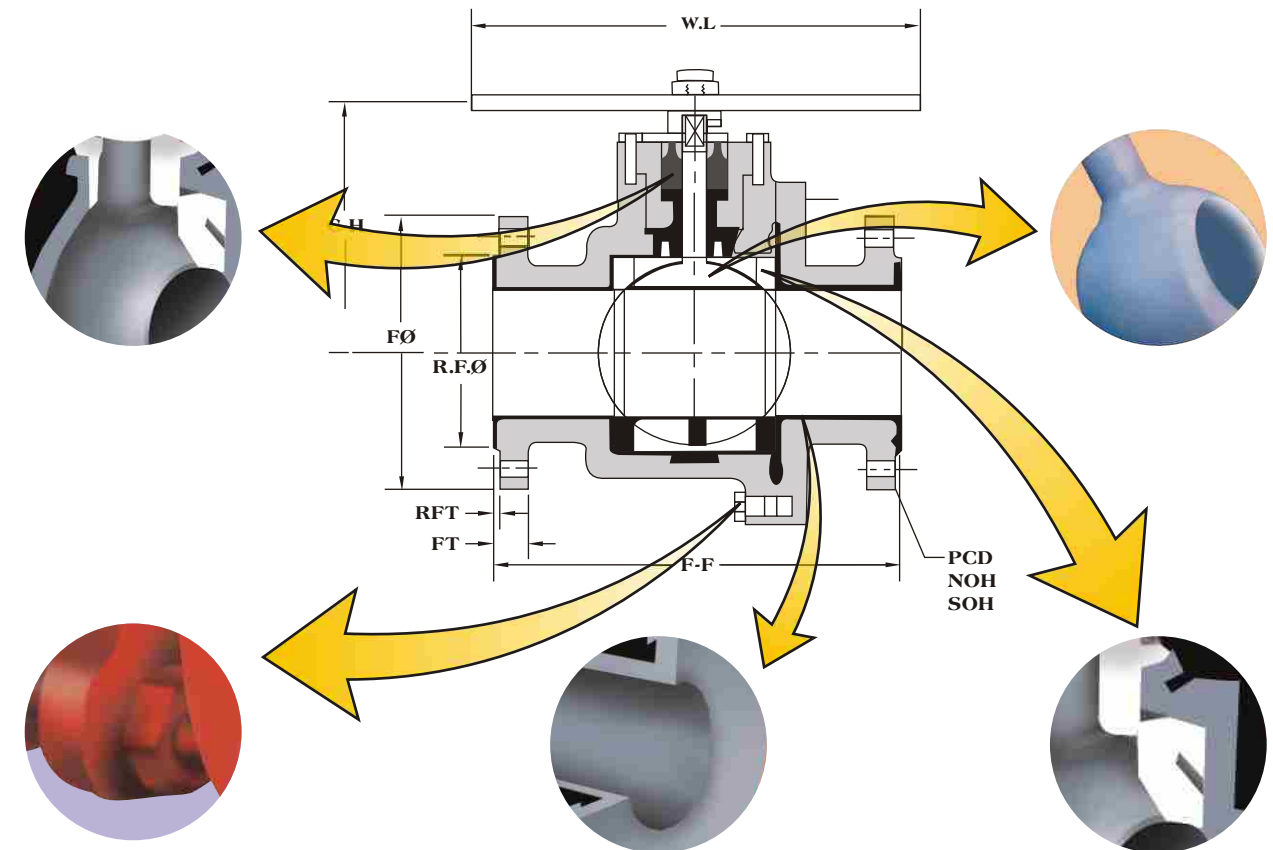

MATERIAL OF CONSTRUCTION:

Description	Material specification	Description	Material specification
Body	Ductile Iron/ WCB /CF8M	Handle Cup	STEEL
Body End		Stud	B7
Ball with Integral Stem		Nut	2H
Seat Ring	PTFE	Hex-Bolt	STEEL
Stem Bearing	PTFE	Socket-Head screw	STEEL
Gland Box	DUCTILE IRON	Stopper Plate	STEEL
Bush	PTFE	Hex-Bolt	STEEL
Gland Packing	PTFE	Lever Rod	STEEL
Gland Nut	ASTM A 276 TYPE 316	Lining	FEP / PFA
Gasket	PTFE		

RASAI Ball Valves' meticulously planned Design is blown out for you to compare and contrast the same with other global valve manufacturers.

DIMENSIONAL DETAILS

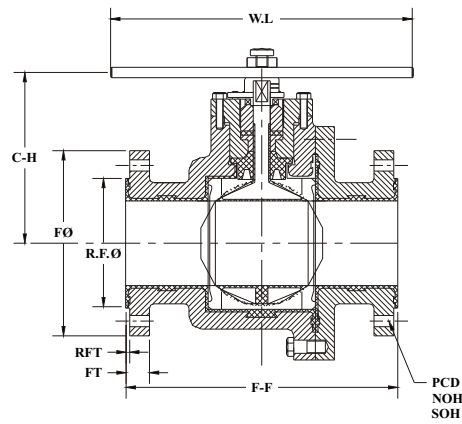

CLASS 300#, DIN STANDARD WILL BE 3 PIECE DESIGN



The face to face dimension and drilling will be as per DIN and Class 300 std.

British Unit

all dimensions in Inches

Size	F-F		FØ		F.T		RFØ	RFT	P.C.D		NOH		SOH		W.L	G.L	C-H	
	CLASS		CLASS		CLASS				CLASS		CLASS		CLASS				CLASS	
	150#	300#	150#	300#	150#	300#			150#	300#	150#	300#	150#	300#			150#	300#
1/2	4.25	5.50	3.50	3.75	.44	.56	1.38	.125	2.38	2.63	4	4	.63	.63	6.38		2.75	2.88
3/4	4.63	6.00	3.88	4.63	.44	.63	1.69	.125	2.75	3.25	4	4	.63	.75	6.38		2.88	3.00
1	5.00	6.50	4.25	4.88	.44	.69	2.00	.125	3.13	3.50	4	4	.63	.75	8.75		3.50	3.75
1 1/2	6.50	7.50	5.00	6.13	.56	.81	2.88	.125	3.88	4.50	4	4	.63	.88	12.50		4.13	4.38
2	7.00	8.50	6.00	6.50	.63	.88	3.63	.125	4.75	5.00	4	8	.75	.75	18.00		4.50	4.75
2 1/2	8.00	11.13	7.50	8.25	.75	1.13	4.13	.125	5.50	5.88	4	8	.75	.88	24.00		5.13	5.56
3	8.00	11.13	7.50	8.25	.75	1.13	5.00	.125	6.00	6.63	4	8	.75	.88	24.00		5.13	5.56
4	9.00	12.00	9.00	10.00	.94	1.25	6.19	.125	7.50	7.88	8	8	.75	.88	30.00		6.00	6.75
6	10.50	15.88	11.00	12.50	1.00	1.44	8.50	.125	9.50	10.63	8	12	.88	.88		18	7.50	8.50
8	11.50	16.50	13.50	15.00	1.13	1.63	10.63	.125	1.75	13.00	8	12	.88	1.00		18	9.00	10.00

Metric Unit

all dimensions in Millimetre

Size	F-F		FØ		F.T		RFØ	RFT	P.C.D		NOH		SOH		W.L	G.L	C-H	
	CLASS		CLASS		CLASS				CLASS		CLASS		CLASS					
	150#	300#	150#	300#	150#	300#			150#	300#	150#	300#	150#	300#			150#	300#
15	108	140	89	95	11	14	35	3	60	67	4	4	16	16	152		70	73
20	117	152	98	118	11	16	43	3	70	83	4	4	16	19	152		73	76
25	127	165	108	124	11	17	51	3	79	89	4	4	16	19	178		89	95
40	165	190	127	156	14	21	73	3	98	114	4	4	16	22	229		105	111
50	178	216	152	165	16	22	92	3	121	127	4	8	19	19	305		114	121
65	203	283	190	210	19	29	105	3	140	149	4	8	19	22	457		130	141
80	203	283	190	210	19	29	127	3	152	168	4	8	19	22	457		130	141
100	229	305	229	254	24	32	157	3	190	200	8	8	19	22	762		152	171
150	267	403	279	318	25	37	216	3	241	270	8	12	22	22		224	190	216
200	292	419	343	381	29	41	270	3	298	330	8	12	22	25		406	229	254

LEGEND

F-F	FACE TO FACE	NOH	NUMBER OF HOLES
FØ	FLANGE DIAMETRE	SOH	SIZE OF HOLE
F-T	FLANGE THICKNESS	W.L	WRENCH LENGTH
RFØ	RAISED FACE DIAMETRE	G.L	GEAR LENGTH
RFT	RAISED FACE THICKNESS	C-H	CENTRE OF FLANGE TO HEIGHT OF BODY
P.C.D	PITCH CIRCLE DIAMETRE		

TORQUE AND Cv VALUE

For CLASS 150#

Size	Break - Away Torque inch Lbs (Nm)	Flow Rate (Value)	
		Cv	Kv
1	75 (8.5)	41	35
1.5	245 (28)	173	147
2	305 (35)	317	263
3	565 (64)	682	580
4	870 (98)	1495	1270
6	2150 (243)	3558	3025

TORQUE

- Start - Break - Away Torque
- Running - 60% of B.A.T
- Close - 80% of B.A.T
- To obtain - Kv Value multiply Cv Value by 0.85

HOW TO ORDER YOUR LINED BALL VALVE ?

VALVE TYPE

LBV	LINED BALL VALVE
-----	------------------

BODY / END PIECE MATERIAL

02	DI
03	WCB
04	SS 316 (CF8M)

SIZES

SIZES	INCHES	MM
0050	1/2"	15
0075	3/4"	20
0100	1"	25
0150	1 1/2"	40
0200	2"	50
0300	3"	80
0400	4"	100
0600	6"	150
0800	8"	200
1000	10"	250
1200	12"	300
1400	14"	350
1600	16"	400

Example*

Lined Ball Valve	LBV
Class 150#	1
DI Body	02
DI Ball	02
FEP Lining	B
Wrench Operation	W
Flanged End	FE
Size 1/2"	0050

BALL

02	DI
03	WCB
04	SS 316 (CF8M)

PRESSURE CLASS

1	150#
3	300#
6	600#

LINING

A	PFA
B	FEP

OPERATION

W	WRENCH OPERATED
G	GEAR OPERATED

END CONNECTION

FE	FLANGED END
----	-------------

SPECIFY THE FOLLOWING WITH PART NUMBERS:

Lined Ball Valve, Class, Body, Ball, Lining, Operation, End Connection, Size.

*EXAMPLE:
LBV10202BWF0050

Lined Ball Valve, Class 150#, Body – Ductile Iron ASTM A 395, Ball – Ductile Iron ASTM A 395, Lining-FEP (Fluorinated Ethylene Propylene), Wrench Operation, End Connection – Flanged End, Size – 1/2".

RASAI's Elastomer Super Seat® is our specialty.

Copy Right March 2001
V. Ravichandran
All rights reserved